

HAKEL GAS DISCHARGE TUBES - SALIENT FEATURES

- * Stable breakdown voltage
- * High insulation resistance; enables the use in high temperature and humidity
- * Small capacitance; minimises transmission loss and noise even with high frequency range
- * High durability against surges and fast restorability
- * Long life
- * Free of radioactive substance
- * Inexpensive for superior performance
- * High mechanical strength prevents leak and breakdown from strong shock
- * Various types available

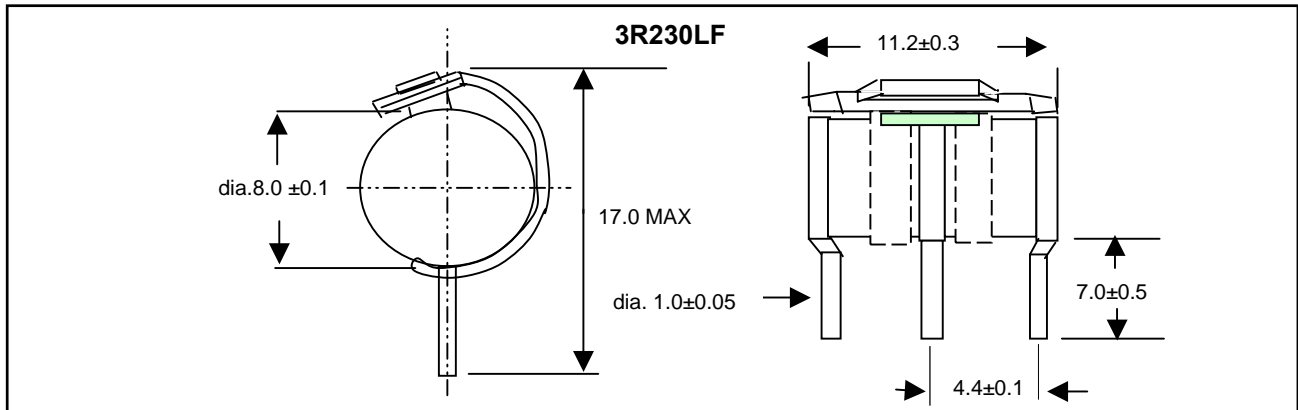

Type 3 TERMINAL CERAMIC TYPE GD TUBE - 3R230LF			
Sl. No.	Description	Test Condition	Specification
ELECTRICAL CHARACTERISTICS, Test Methods as per ITU-T (CCITT) K.12			
1	D.C Spark-Over Voltage	100V/Sec	230 ±20%
2	Impulse Spark-Over Voltage	100V/μsec	<500V
3	Impulse Spark-Over Voltage	1000V/μsec	<650V
4	Impulse Transverse Delay	1000 V/μ sec	< 75ns
5	Insulation Resistance	100V	>10 ¹⁰ Ohm
6	Glow Voltage	10 mA	< 70 V
7	Arc Voltage	2 A	< 10 V
8	Capacitance	1 M Hz	< 1.5 pF
9	DC Holdover Voltage	135 V	< 150 ms
10	Impulse Discharge Current	10000 A, 8/20μsec	10 Operations
		200 A, 10/700μsec	500 Operations
		200 A, 10/1000μsec	300 Operations
11	Alternating Discharge Current	10 A r.m.s, 1 sec	10 Operations
12	Fail-safe Operating Time	10 A r.m.s	< 5 Sec

NOTES:

1. All dimensions are in mm
 2. Electrodes are nickel plated where as all lead terminals are Tin plated.
 3. Marking on the GD Tube
 - 3R230LF
 - 3 : 3 Terminal GD Tube
 - R : Dimension
 - 230 : 230 Volts
 - L : With leads
 - F : With Fail-safe Mechanism
- HAKEL : Manufacturer
 MM : Month of manufacture
 YY : Year of manufacture

4. This model can be supplied without Leads, namely 3R230F
5. Blister Packing