

- 35 mm DIN rail mount, EN 50022 or on panel mounting
- Interface relay **PI85** consists of: PCB relay type **RM85**, plug-in socket **GZT80**, signalling or protecting module type **M...**: M41G or M43G or M91G or M93G (see page 170), retainer / retractor clip **GZT80-0040**, white description plate **GZT80-0035**

Contacts

Contact number & arrangement		1C/O
Contact material		AgNi
Max. switching voltage	AC/DC	400 V / 300 V
Min. switching voltage		5 V
Rated load	AC1	16 A / 250 V AC
	DC1	16 A / 24 V DC
Min. switching current		5 mA
Max. inrush current		30 A
Rated current		16 A
Max. breaking capacity	AC1	4 000 VA
Min. breaking capacity		0,3 W
Resistance		≤ 100 mΩ
Max. operating frequency		
• at rated load	AC1	600 cycles/hour
• no load		72 000 cycles/hour

Coil

Rated voltage	50/60 Hz AC	12- 24 -120- 230 V
	DC	12- 24 -110 V
Must release voltage		AC: ≥ 0,15 U _n DC: ≥ 0,1 U _n
Operating range of supply voltage		see Table 1, 2 and Fig. 4, 5
Rated power consumption	AC	0,75 VA
	DC	0,4...0,48 W

Insulation

Insulation category		C250
Insulation rated voltage		400 V AC
Dielectric strength		
• coil - contact		5 000 V AC
• contact - contact		1 000 V AC
Contact - coil distance		
• clearance		≥ 10 mm
• creepage		≥ 10 mm

General data

Operating time (typical value)		7 ms
Release time (typical value)		3 ms
Electrical life		
• resistive AC1		> 0,7 x 10 ⁵ 16 A, 250 V AC
• cos φ		see Fig. 2
• L/R=40 ms		> 10 ⁵ 0,12 A, 220 V DC
Mechanical life (cycles)		> 3 x 10 ⁷
Dimensions (L x W x H)		75,3 x 15,5 x 67 mm
Weight		62 g
Ambient temperature		
• storing		-40...+85 °C
• operating		AC: -40...+70 °C DC: -40...+85 °C
Protection category		
• cover		IP 40
• terminals		IP 20
Shock resistance		30 g
Vibration resistance		10 g 10...150 Hz

Standard contact material and standard coil rated voltages marked with bolt type.



Coil data - DC voltage version

Table 1

Coil code	Rated voltage V DC	Coil resistance ±10% at 20 °C Ω	Coil operating range at 20 °C V DC	
			min.	max.
12DC	12	360	8,4	30,6
24DC	24	1 440	16,8	61,2
110DC	110	25 200	77,0	280,0

Standard coil rated voltages marked with bold type.

Coil data - AC 50/60 Hz voltage version

Table 2

Coil code	Rated voltage V AC	Coil resistance ±10% at 20 °C Ω	Coil operating range at 20 °C V AC	
			min.	max.
12AC	12	100	9,6	13,2
24AC	24	400	19,2	26,4
120AC	120	10 200	96,0	144,0
230AC	230	38 500	184,0	253,0

Standard coil rated voltages marked with bold type.

Dimensions

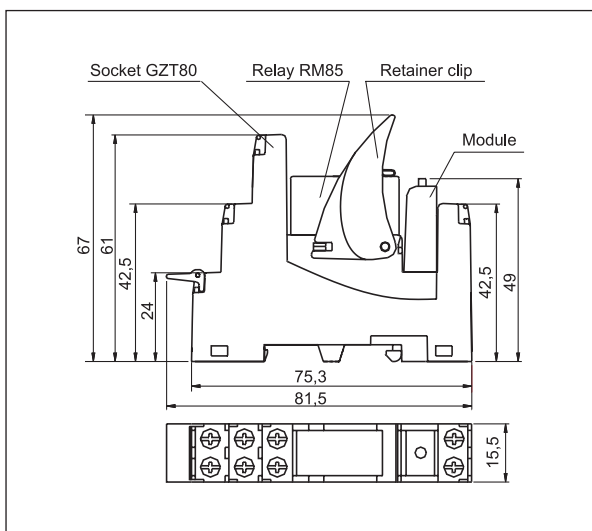

Connections diagrams (pin side view)

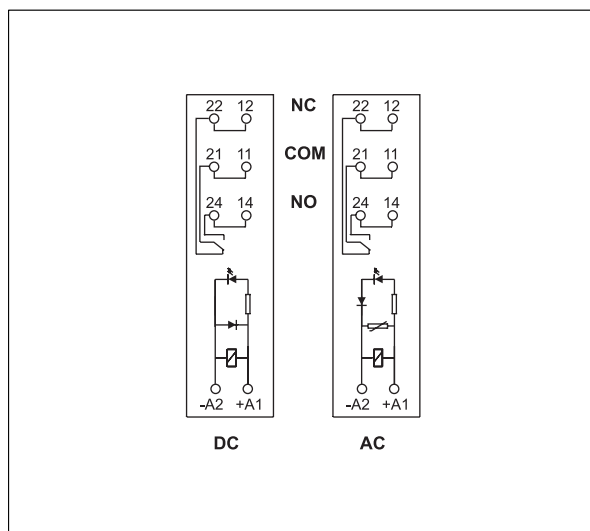

Connection of GZT80

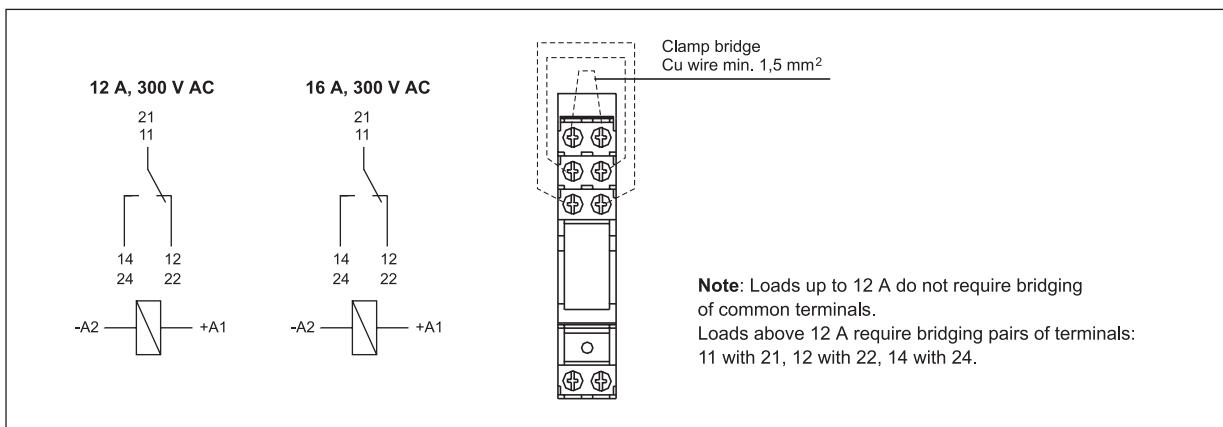

Electrical life at AC resistive load

Fig. 1

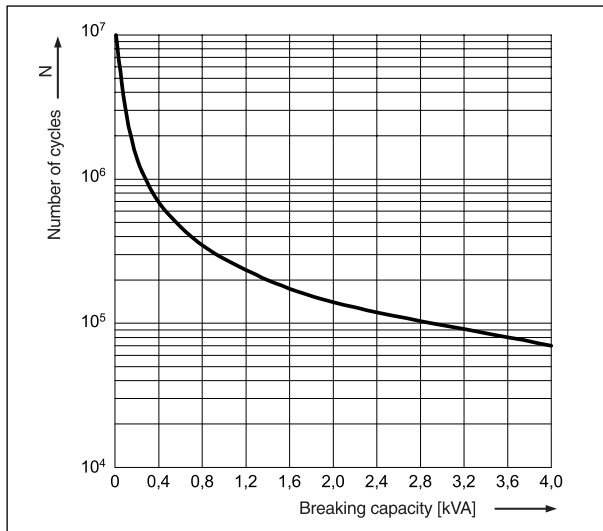

Electrical life reduction factor at AC inductive load

Fig. 2

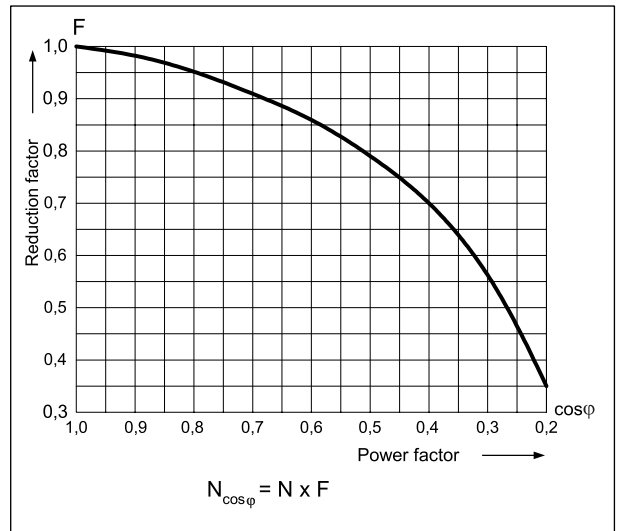

Max. DC resistive load breaking capacity

Fig. 3

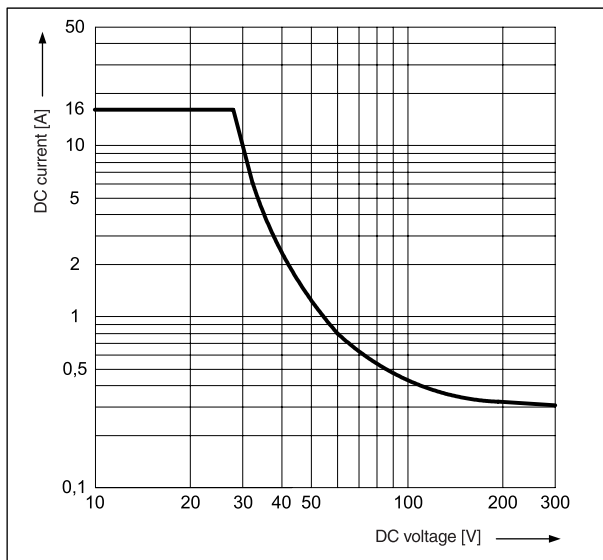

Coil operating range - DC

Fig. 4

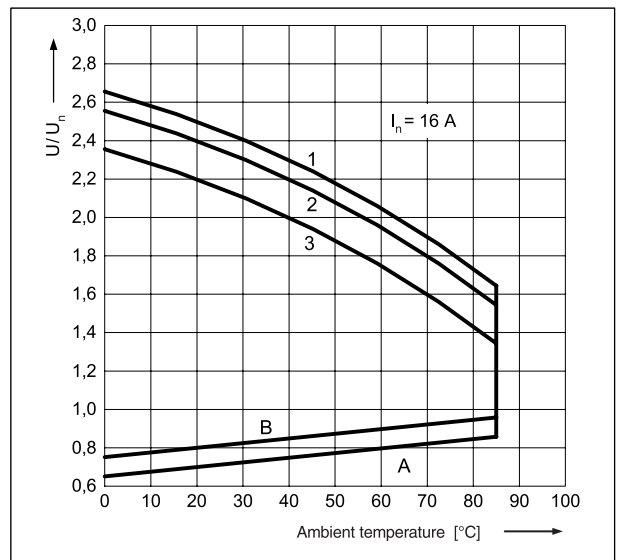

Coil operating range - AC

Fig. 5

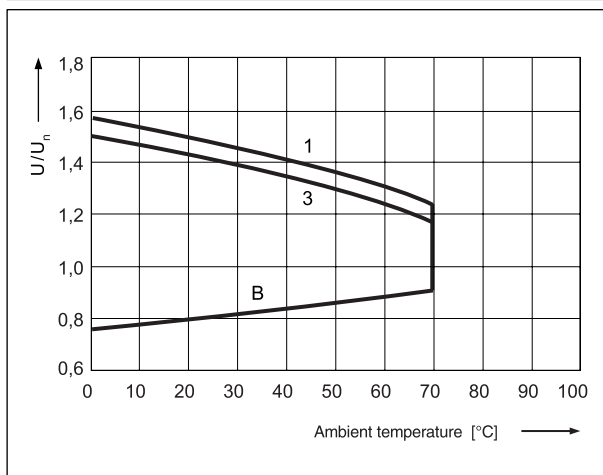

Description of Fig. 4 and 5

A - relations between make voltage and ambient temperature at no load on contacts. Coil temperature and ambient temperature are equal before coil energizing. Make voltage is not higher than the value read on Y axis (multiplication of rated voltage).

B - relations between make voltage and ambient temperature after initial coil heating up with $1,1 U_n$, at continues load of I_n on contacts. Make voltage is not higher than the value read on Y axis (multiplication of rated voltage).

1, 2, 3 - values on Y axis represent allowed overvoltage on coil at certain ambient temperature and contact load:

- 1 - no load
- 2 - 50% of rated load
- 3 - rated load



Mounting

Relays **PI85** are designed for mounting on 35 mm DIN rail mount, EN 50022 or on panel.

Ordering codes

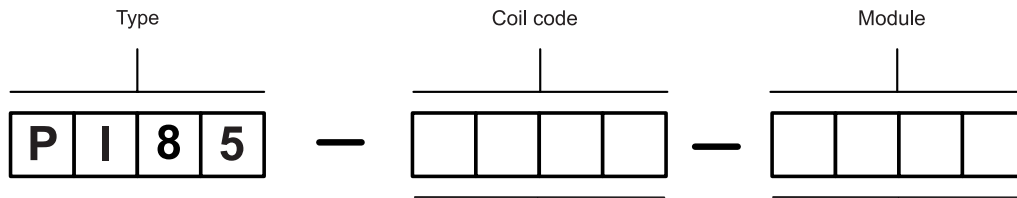

see Table 1, 2 page 133

- M41G - D + LED green 6/24 V DC
- M43G - D + LED green 110/230 V DC
- M91G - LED green + varistor 6/24 V AC
- M93G - LED green + varistor 110/230 V AC

