

- ▶ Front panel mounting
- ▶ Width 45mm
- ▶ 8 functions
- ▶ 1 change over contact



Technical data

1. Functions

- A ON delay
- A2 ON delay, power failure detection
- B ON delay with control contact
- C OFF delay with control contact
- D Single shot leading edge with control contact
- E ON delay, pulse operated
- F Flasher pause first
- G ON delay with control contact, adding, power failure detection

2. Time ranges

Direction of time period selectable by DIP-Switch

	Adjustment range	
1	0.001s	9.999s
2	0.01s	99.99s
3	0.1s	999.9s
4	1s	9999s
5	0min1s	99min59s
6	0.1min	999.9min
7	0h1min	99h59min
8	0.1h	999.9h

3. Indicators

- OP: indication of relay output
- RESET: RESET indicator
- LOCK: LOCK indicator
- 4-digit LC display (red): indication of time period
- 4-digit LC display (yellow): Preset value

4. Mechanical design

Self-extinguishing plastic housing, IP rating IP66
 Mounted in front panel aperture 45 x 45mm by means of retaining clip (included) according to DIN 43700
 (screw terminal socket for panel mounting type TVC11 or R11X - not included)
 Mounting position: any

5. Input circuit

- Supply voltage:
 - 24V AC/DC pins 2-10(+) (FSM10 24V AC/DC)
 - 100 to 240V AC pins 2-10 (FSM10 100-240V AC)
- Tolerance:
 - 24V AC/DC -15% to 10%
 - 100 to 240V AC -15% to 10%
- Rated frequency: 48 to 63Hz
- Rated consumption:
 - 24V AC/DC 10W
 - 230V AC 10W
- Duration of operation: 100%
- Reset time: 500ms
- Residual ripple for DC: 20%
- Drop-out voltage: >30% of supply voltage

6. Output circuit

- 1 potential free change over contact
- Switching capacity: 1250VA (5A / 250V AC)
- Fusing: 8A fast acting

- Mechanical life: 20 x 10⁶ operations
- Electrical life: 1 x 10⁵ operations at 1000VA resistive load
- Switching frequency: max. 60/min at 100VA resistive load max. 6/min at 1000VA resistive load (according to IEC 947-5-1)
- Insulation voltage: 250V AC (according to IEC 664-1)
- Surge voltage: 4kV, overvoltage category III (according to IEC 664-1)

7. Control contact

- Contact: have to be switched potential free, pins 3-4, 3-5, 3-6, 3-7
- Loadable: No
- Line length: -
- Control pulse length:
 - DC min. 1ms (LOCK) or min. 1ms or 20ms (SIGNAL, RESET, STOP)
 - AC min. 1ms (LOCK) or min. 1ms or 20ms (SIGNAL, RESET, STOP)

8. Accuracy

- Base accuracy: <0.005%
- Adjustment accuracy: -
- Repetition accuracy:
 - ± (0.005% + 50ms) start with supply voltage
 - ± (0.005% + 20ms) start with RESET or SIGNAL
- Temperature influence: -

9. Ambient conditions

- Ambient temperature: -10 to +55°C
- Storage temperature: -10 to +70°C
- Transport temperature: -10 bis +70°C
- Relative humidity: 15% to 85% (according to IEC 721-3-3 Class 3K3)
- Pollution degree: 2, if built in 3 (according to IEC 664-1)

10. Accessories

- TVC11, R11X

Dimensions

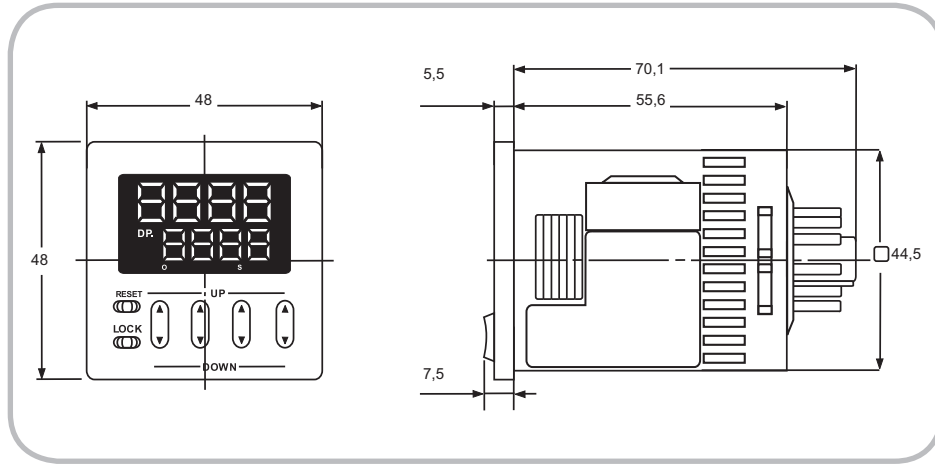

Functions

ON delay (A)

When the supply voltage U is applied, the value of the time already expired is cleared and the set time t begins to run (display for time lapse flashes, counting runs either by adding or subtracting). After expiry of the time t , the output relay R picks up (OP display lights up) and the set time t (adding) or the value 0 (subtracting) is shown in the display. The status is maintained until the supply voltage is interrupted.

A new time lapse can be started at any time by applying a signal at the RESET function input. The time lapse can be interrupted for any length of time by applying a signal at the STOP function input. If no signal is applied to the function input, the time lapse continues. Signals at the SIGNAL function input are ignored for this particular function.

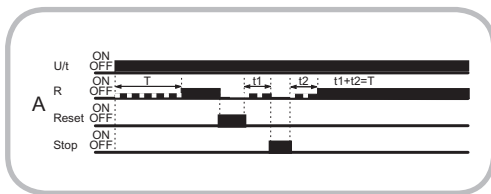

ON delay, power failure detection (A2)

When the supply voltage U is applied, the value of the time already expired is not cleared (power failure recognition) and the time lapse is continued or restarted (display for time lapse flashes, counting runs either by adding or subtracting). After expiry of the set time t , the output relay R picks up (OP display lights up) and the set time t (adding) or the value 0 (subtracting) is shown in the display. If the supply voltage is interrupted, both the expired time t up to this point and the relay position are saved (power failure recognition).

A new time lapse can be started at any time by applying a signal at the RESET function input. The time lapse can be interrupted for any length of time by applying a signal at the STOP function input. If no signal is applied at the STOP function input, the time lapse continues. Signals at the SIGNAL function input are ignored for this particular function.

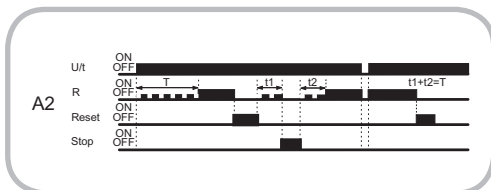

ON delay with control contact (B)

The supply voltage U must be constantly applied to the device. When the supply voltage is applied the value of the time already expired is cleared. When a signal is applied at the SIGNAL function input, the set time t begins to run (display for time lapse flashes, counting runs either by adding or subtracting). After expiry of the time t , the output relay R picks up (OP display lights up) and the set time t (adding) or the value 0 (subtracting) is shown in the display. This status is maintained until the signal at the SIGNAL function input is removed again.

Applying a signal at the RESET function input releases the output relay (OP display does not light up) and the time already expired is cleared. A new time lapse is started by applying a signal at the SIGNAL function input.

The time lapse can be interrupted for any length of time by applying a signal at the STOP function input. If no signal is applied at the STOP function input, the time lapse continues.

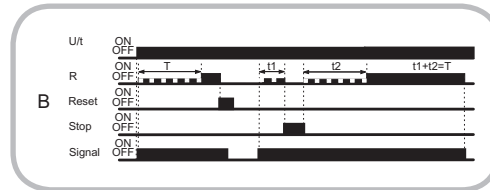

OFF delay with control contact (C)

The supply voltage U must be constantly applied to the device. When the supply voltage is applied the value of the time already expired is cleared. When a signal is applied at the SIGNAL function input, the output relay R picks up (OP display lights up). If the signal at the SIGNAL function input is removed, the set time t begins to run (display for time lapse flashes, counting runs either by adding or subtracting). After expiry of the time t , the output relay releases (OP display is deleted) and the set time t (adding) or the value 0 (subtracting) is shown in the display. If another signal is applied at the SIGNAL function input before the expiry of the set time t , the time already expired is cleared and the process restarts with the next cycle.

Applying a signal at the RESET function input releases the output relay (OP display does not light up) and the time already expired is cleared. A new time lapse is started by applying a signal at the SIGNAL function input.

The time lapse can be interrupted for any length of time by applying a signal at the STOP function input. If no signal is applied at the STOP function input, the time lapse continues.

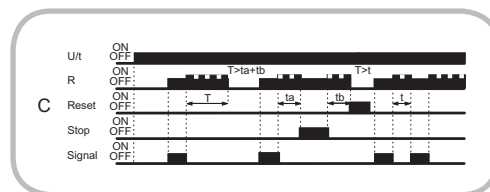

Single shot leading edge with control contact (D)

The supply voltage U must be constantly applied to the device. When the supply voltage is applied the value of the time already expired is cleared. When a signal is applied at the SIGNAL function input, the output relay R picks up (OP display lights up) and the set time t begins to run (display for time lapse flashes, counting runs either by adding or subtracting). After expiry of the time t , the output relay releases (OP display is deleted) and the set time t (adding) or the value 0 (subtracting) is shown in the display. Signals at the SIGNAL function input are ignored during the time lapse.

Applying a signal at the RESET function input releases the output relay (OP display does not light up) and the time already expired is cleared. A new time lapse is started by applying a signal at the SIGNAL function input.

Functions

The time lapse can be interrupted for any length of time by applying a signal at the STOP function input. If no signal is applied at the STOP function input, the time lapse continues.

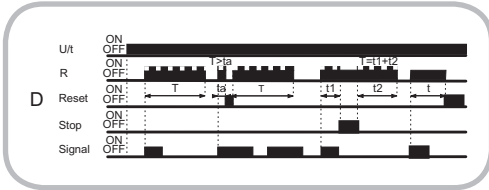

On delay, pulse operated (E)

The supply voltage U must be constantly applied to the device. When the supply voltage is applied the value of the time already expired is cleared. When a signal is briefly applied at the SIGNAL function input, the set time t begins to run (display for time lapse flashes, counting runs either by adding or subtracting). After expiry of the time t, the output relay R picks up (OP display lights up) and the set time t (adding) or the value 0 (subtracting) is shown in the display.

Signals at the SIGNAL function input are ignored during the time lapse.

Applying a signal at the RESET function input releases the output relay (OP display does not light up) and the time already expired is cleared. A new time lapse is started by applying a signal at the SIGNAL function input.

The time lapse can be interrupted for any length of time by applying a signal at the STOP function input. If no signal is applied at the STOP function input, the time lapse continues.

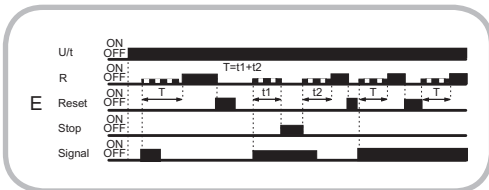

Flasher pause first (F)

The supply voltage U must be constantly applied to the device. When the supply voltage is applied the value of the time already expired is cleared. When a signal is applied at the SIGNAL function input, the set time t begins to run (display for lapse time flashes, counting runs either by adding or subtracting). After expiry of the time t, the output relay R picks up (OP display lights up) and the set time t (adding) or the value 0 (subtracting) is shown in the display.

The output relay is triggered in the ratio 1:1 until the supply voltage is interrupted. Signals at the SIGNAL function input are ignored during the time lapse.

Applying a signal at the RESET function input releases the output relay (OP display does not light up) and the time already expired is cleared. A new time lapse is started by applying a signal at the SIGNAL function input.

The time lapse can be interrupted for any length of time by applying a signal at the STOP function input. If no signal is applied at the STOP function input, the time lapse continues.

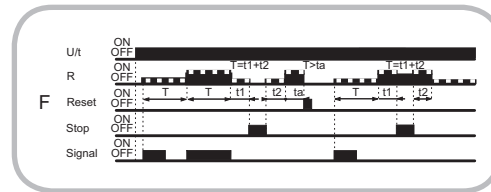

On delay with control contact, adding, power failure detection (G)

When the supply voltage U is applied, the time already expired is not cleared (power failure recognition).

When a signal is applied at the SIGNAL function input, the time lapse continues (display for time lapse flashes, counting runs either by adding or subtracting). After expiry of the set time t, the output relay R picks up (OP display lights up) and the set time t (adding) or the value 0 (subtracting) is shown in the display.

If the signal at the SIGNAL function input or the supply voltage is interrupted, both the expired time t up to this point and the relay position are saved (power failure recognition).

A new time lapse can be started at any time by applying a signal at the RESET function input.

The time lapse can be interrupted for any length of time by applying a signal at the STOP function input. If no signal is applied at the STOP function input, the time lapse continues.

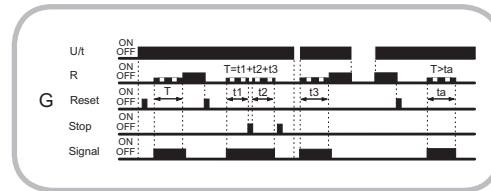

Connections

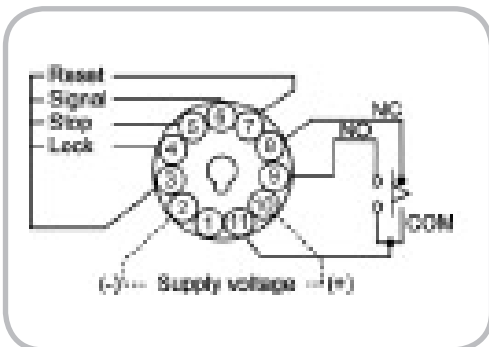

 **Comments**